



YOSHIMURA

RESEARCH&DEVELOPMENT OF AMERICA, INC.

5420 DANIELS STREET STE A, CHINO CA., 91710 · (800)634-9166 · (909)628-4722 · FACSIMILE (909)591-2198

www.yoshimura-rd.com

YOSHIMURA PERFORMANCE HARDPARTS

SUZUKI
2009-2012
GSX-R1000

YS1-LINK-KIT YOSHIMURA SUSPENSION LINKAGE KIT

**Note: This product can ONLY be used with Yoshimura Full Exhaust Systems. The linkage geometry will not clear stock or slip-on exhaust systems.*

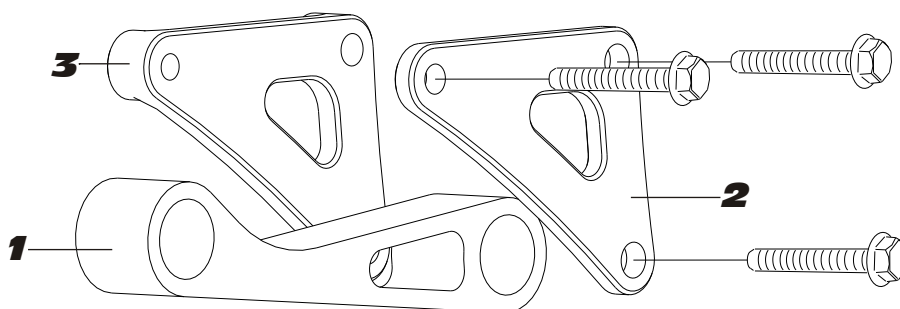
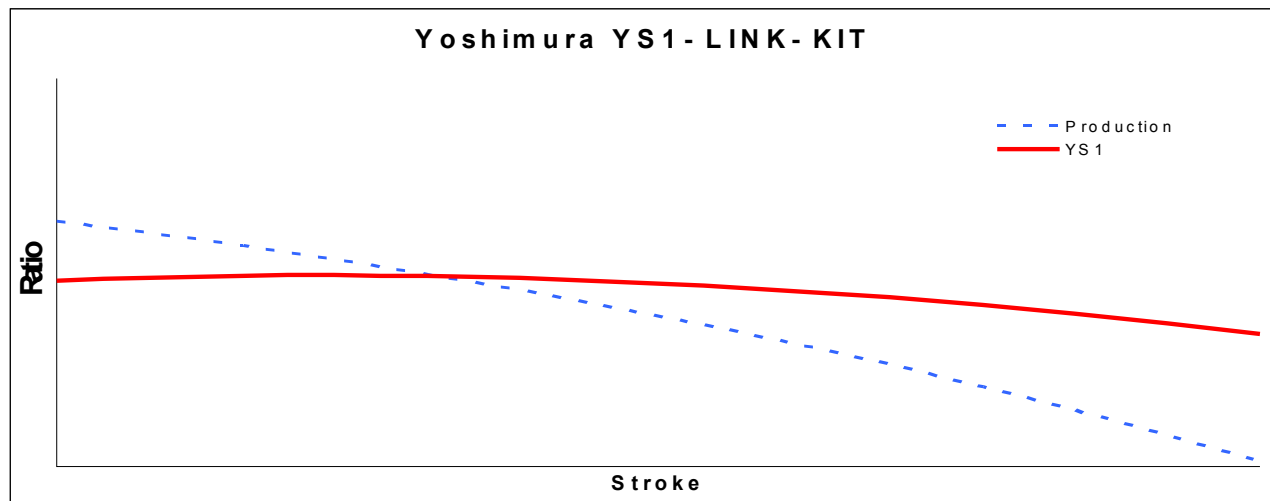

Part List:

#	DESCRIPTION	QTY	PART #
1	GSXR1K 09 159MM Control Link	1	YS1-CLINK
2	GSXR1K 09 159MM Left Bracket	1	YS1-LINK-L
3	GSXR1K 09 159MM Right Bracket	1	YS1-LINK-R
**	Yoshimura Sticker Kit Sheet	1	17029



THIS PRODUCT IS DESIGNED FOR USE IN CLOSED COURSE RACING AND IS NOT INTENDED FOR HIGHWAY USE.



Caution: Exhaust system can be extremely hot. Let motorcycle cool down before beginning installation. Always wear hand and eye protection and take precautionary measures to avoid injury.

Note: Read through all instructions before beginning installation.

Tools Needed:

Metric Socket Set
3/8" ratchet and extension
Metric Combination Wrench Set
Torque Wrench

Installation Steps:

1. Lift bike up on rearstand.
2. Remove rear wheel.
3. Loosen all of the linkage bolts (Fig. 1)
4. Place a jackstand under each rearset peg (If using stock rearsets be sure to place jackstand under the non-folding part of the peg). Remove rearstand so swingarm can move freely.
5. Remove bolts from stock linkage and remove from bike.
6. Orientate Yoshimura side plates so the logos face outwards and right side up.

Note: Inspect bearings to make sure they are clean and free from debris. Lightly lubricate with grease.

7. Attach the Yoshimura control link to the side plates using the stock bolt. (Note: The Yoshimura logo on the control link should be closer towards the front of the bike.)
8. Install the Yoshimura suspension linkage assembly using stock bolts. Do not torque at this time.
9. Lift bike up on rearstand.
10. Torque the 4 linkage bolts to 29 lb-ft (40 Nm)
11. Reinstall rear wheel. Torque to factory specifications.
12. Check all clearances. Make sure that suspension is operating smoothly and is free from any binding. If any problem is found, please carefully follow through the installation steps again. If problem still persists, please call Yoshimura technical department at (800)634-9166 / in CA (909)628-4722.

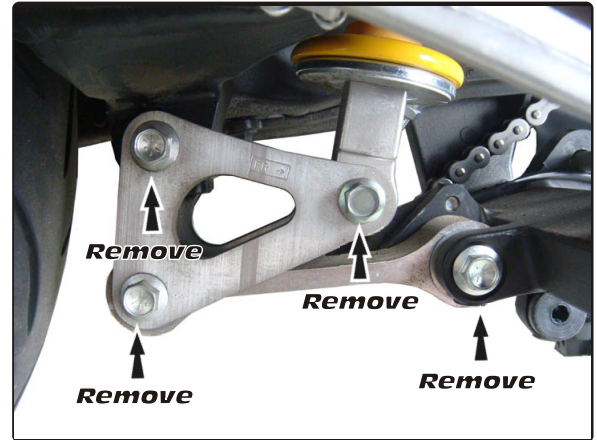

Fig. 1

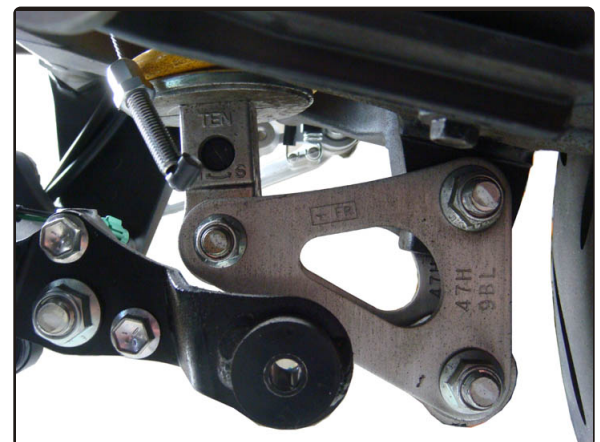

Fig. 2