



YOSHIMURA

RESEARCH&DEVELOPMENT OF AMERICA, INC.

5420 DANIELS STREET STE A, CHINO CALIF. 91786 · (800)634-9166 · (909)628-4722 · FACSIMILE (909)591-2198

www.yoshimura-rd.com

Adjustable Rearset Bracket Kit

Kawasaki
2008-2012 Ninja 250R
2013-2014 Ninja 300

PN: R-K930-K

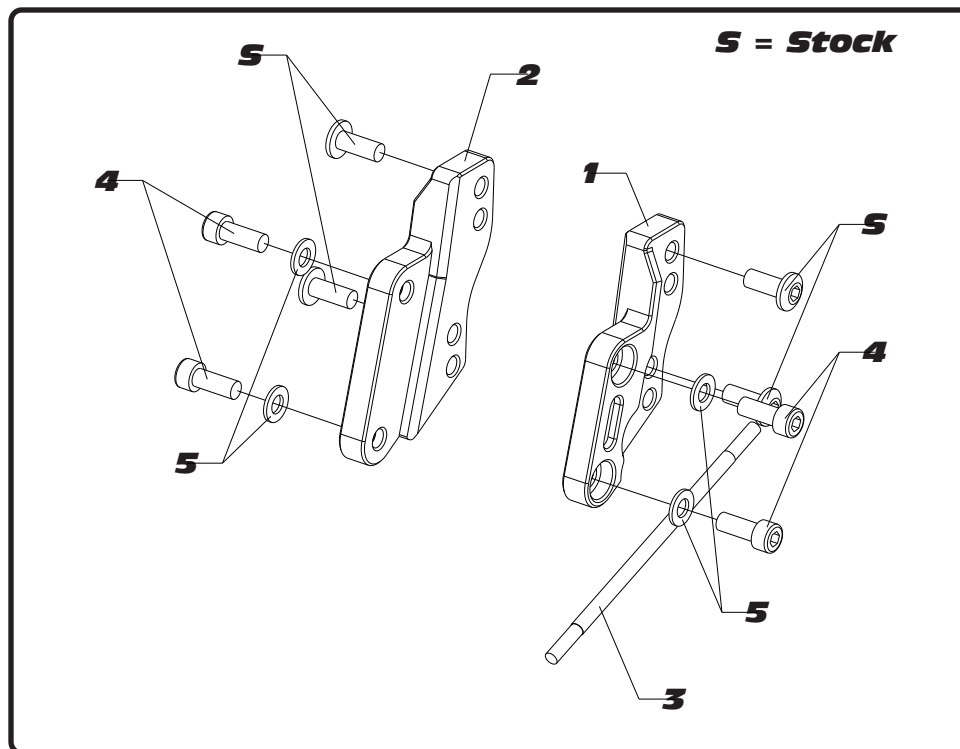

Parts Diagram

Parts List:

	DESCRIPTION	QTY	PART #
1	Left Rearset Bracket	1	R-K930BPL-00
2	Right Rearset Bracket	1	R-K930BPR-00
3	Shift Link Rod	1	R-K8SR158SS
4	8mm x 20mm Socket Bolt	4	M8X20
5	8mm Flat Washer	4	8MMWASHER-SS
**	Thread Lock Adhesive	1	R-K880ND
**	Yoshimura *USA* Sticker	2	17020C

Adjustable Positions:

Upper Position	Back	43mm
	Up	35mm
Lower Position	Back	43mm
	Up	20mm

Caution: Always wear proper protective gear when performing work on vehicles.

Note: Read through all instructions before beginning installation.

Tools Needed:

6mm Hex Bit and Ratchet
10mm Open Ended Wrench
Torque wrench
Tube Cutter

Installation Steps:

1. Remove stock shifter rod by loosening shift rod lock nuts and removing shift arm. Remove stock right rearset from frame by removing 2 bolts.
2. Clean stock bolts and apply a medium strength thread lock (included) to stock and supplied bolts. See parts diagram to install Yoshimura right rearset bracket to frame using supplied bolts and washer. Install stock rearset onto desired position (See Fig. 1). See chart on front page for positions available.

Torque to 18.5 ft-lbs (25 N-m).

Note: Stock bolts will be used on stock rearset to Yoshimura rearset bracket. Supplied bolts and washers are to be used to mount Yoshimura rearset bracket and frame.

3. Remove stock lock nuts from stock shift rod and install onto Yoshimura shift rod. Install Yoshimura shift rod onto shift lever and shift arm. **Be sure to check position and clearance of shift lever action before operating motorcycle.** Tighten lock nuts.
4. Remove right rearset by removing stock bolts.
5. Clean stock bolts and apply a medium strength thread lock (included) to stock and supplied bolts. See parts diagram to install Yoshimura right rearset bracket to frame using supplied bolts and washer. Install stock rearset onto desired position (See Fig. 2). See chart on front page for positions available.

Note: Stock bolts will be used on stock rearset to Yoshimura rearset bracket. Supplied bolts and washers are to be used to mount Yoshimura rearset bracket and frame.

Torque to 18.5 ft-lbs (25 N-m).

6. The rear brake reservoir hose will need to be shortened by 65mm so as not to cause binding and/or contact with other components. Remove rear brake reservoir hose, being sure not to spill brake fluid over painted or coated surfaces. Shorten the reservoir hose using tube cutter or sharp scissors. Reconnect hose and top off rear brake reservoir.

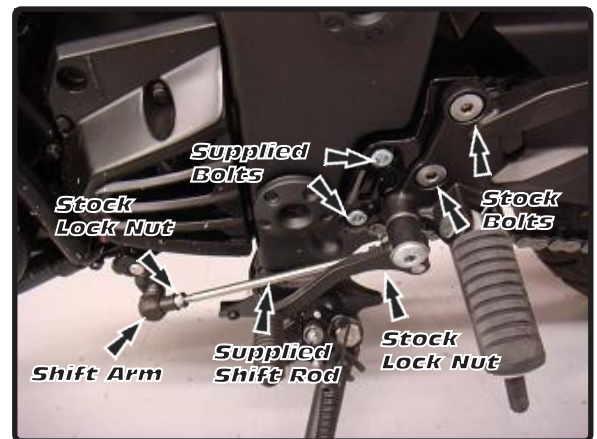

Fig. 1

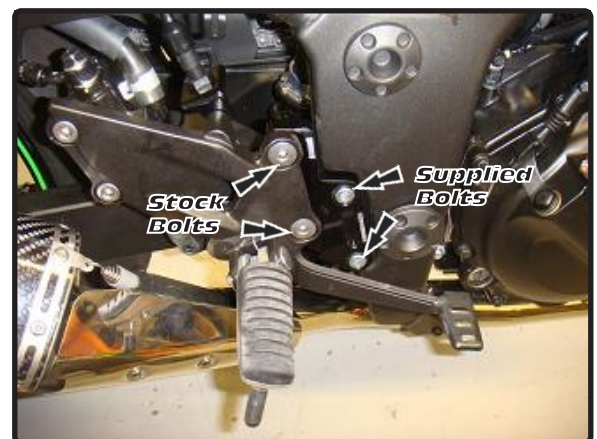

Fig. 2