



# YOSHIMURA

RESEARCH&DEVELOPMENT OF AMERICA, INC.

5420 DANIELS STREET STE A, CHINO CALIF. 91710 · (800)634-9166 · (909)628-4722 · FACSIMILE (909)591-2198

[www.yoshimura-rd.com](http://www.yoshimura-rd.com)

## YOSHIMURA CASE SAVER KIT

**2006-2012**  
**Yamaha**  
**YZF-R6V**

**R-K475**

YOSHIMURA CASE SAVER KIT

**RIGHT**

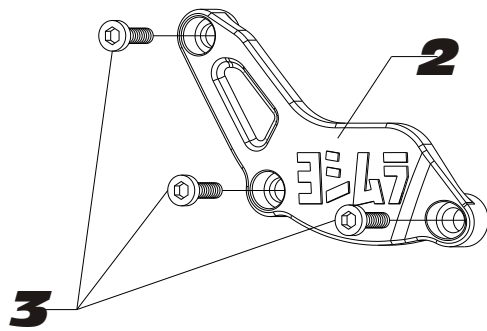

**LEFT**

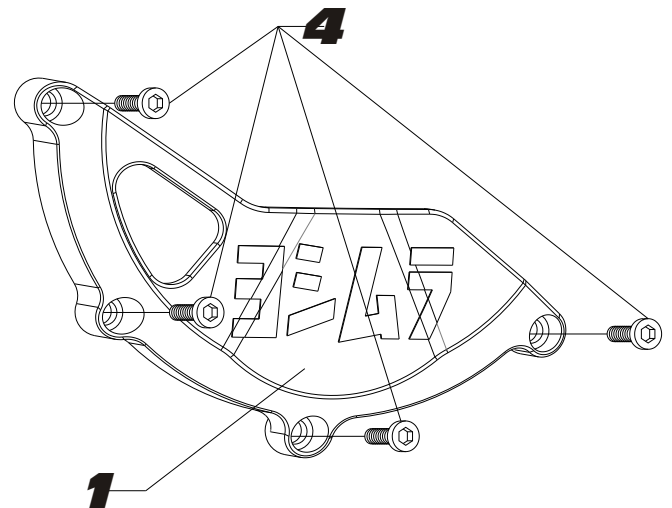

**VIEW FROM FRONT**

### Part List:

NO.	DESCRIPTION	QTY	PART #
1	Left Case Saver	1	R-K475L
2	Right Case Saver	1	R-K475R
3	6mm x 25mm Socket Head Bolt	3	M6X25
4	6mm x 35mm Socket Head Bolt	4	M6X35
**	Yoshimura Sticker	1	17029

Yoshimura Case Savers are designed to reduce damage to the engine cases in the event of a light or mild crash ONLY. The Case Savers are not designed to prevent damage to the engine cases completely, nor are they designed to prevent damage to fairings or body work.

**Note: Read through all instructions before beginning installation be sure to prepare a clean work area. Take necessary safety precautions to ensure a safe working environment. Always use a bike stand whenever available.**

**Tools Needed:**

Metric Socket Set  
Ratchet  
Metric Allen Socket Set  
Torque Wrench

**Installation Steps:**

1. Remove the four stock left side engine cover bolts. Install Yoshimura left side case saver using the three supplied 6mm x 35mm bolts as shown in Figure 1.

**NOTE: DO NOT REMOVE ENGINE COVER.**

2. Torque supplied bolts to 1.1 kg-m (8.0 lb-ft).
3. Remove the three right side engine cover bolts. Install Yoshimura right side case saver using the three supplied bolts. (See parts diagram for bolt locations.) When installing the case saver, make sure the stock harness bracket is mounted between the stock case cover and the case saver in the same position it was removed from.

**NOTE: DO NOT REMOVE ENGINE COVER.** On 2006-2007 models, some trimming of the stock plastic may be necessary for clearance.

4. Torque supplied bolts to 1.1 kg-m (8.0 lb-ft).