





# PERFORMANCE EXHAUST SYSTEM

**APPLICATION**

<b>YEAR</b>	<b>MODEL</b>
2013-2014	Kawasaki Ninja 300

**PRODUCT**

147002J220	R77 SS Slip-On Exhaust with Carbon Fiber Sleeve; Carbon Fiber Endcap
147002J520	R77 SS Slip-On Exhaust with Stainless Steel Sleeve; Carbon Fiber Endcap

-  This product is designed for use in closed course racing and is not intended for highway use. In the state of California, it is illegal to modify the emission control system, which includes the fuel injection of any vehicle.
-  You must know how to remove and replace your stock exhaust in order to install this product otherwise have it installed by a professional mechanic. Keep all stock parts from your existing system as some components may be necessary to install your new Yoshimura exhaust depending on the application.
-  Read through all instructions before beginning installation. Exhaust system can be extremely hot. Let motorcycle cool down before beginning installation. Always wear hand and eye protection and take precautionary measures to avoid injury.

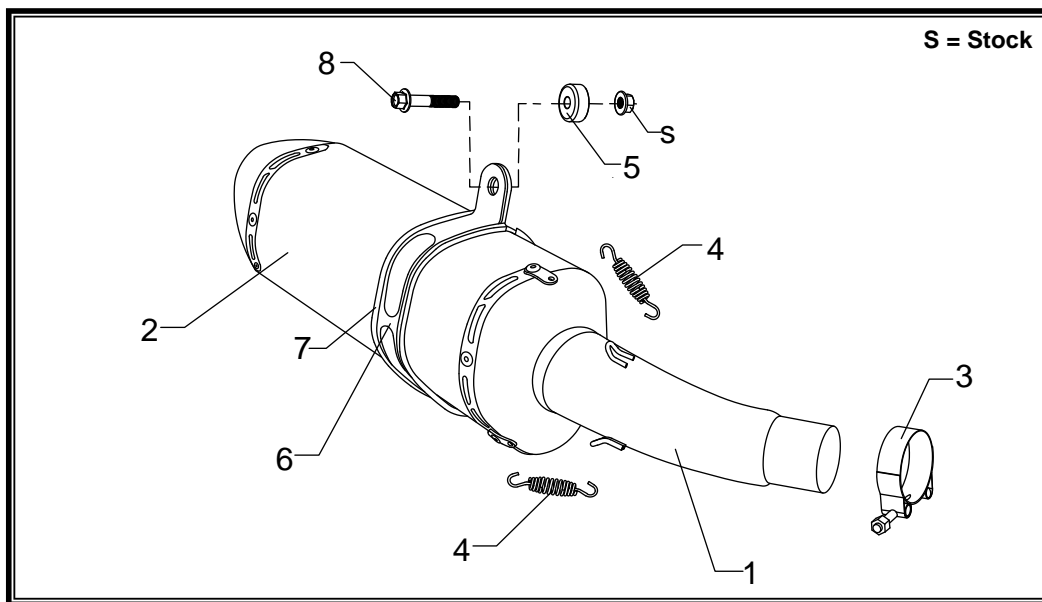

No.	Part #	Description	Qty
1	14700-435	Yoshimura Tailpipe	1
2	CRR77M12 SRR77M12	Yoshimura Muffler Carbon Fiber Sleeve Stainless Steel Sleeve	1
3	22057	Exhaust Clamp	1
4	RACE-SPS-1	Medium Spring	2
5	ALS-035	Aluminum Spacer	1
6	YM7M-MPCA YM7M-MPCAX	Muffler Clamp CF Sleeve SS Sleeve	1
7	HT SHLDR77	Muffler Clamp Heatshield	1
8	M10X70H	10mm x 70mm Flanged Hex Head Bolt	1
**	INS-04-K	Low Volume Insert	1
**	ST-200	Spring Puller Tool	1
**	17029	Yoshimura Sticker Sheet	1

**-TOOLS REQUIRED-**

*Metric Socket Set • Combination Wrench Set • Torque Wrench • Metric Allen Wrench Set*

**-REMOVAL-**

- 1. Remove stock heatshield by removing the heatshield bolt and loosening hose clamp securing stock heatshield to header.**
- 2. Loosen stock exhaust clamp.**
- 3. While securely supporting the stock muffler, remove muffler mount bolt to remove muffler.**

**Note: Stock exhaust gasket will not be used with the Yoshimura slip-on exhaust system.**

**-INSTALLATION-**

- 1. Install rubber heatshield onto muffler clamp.**
- 2. Slide provided exhaust clamp over Yoshimura tailpipe.**
- 3. Install Yoshimura muffler assembly by sliding Yoshimura tailpipe over stock header.**

**Note: Slide Yoshimura tailpipe 80mm over stock header.**

- 4. Slide Yoshimura muffler clamp over muffler and align to stock muffler mount. Install provided 10mm bolt, provided aluminum spacer, and stock nut. See diagram for proper orientation.**

**Note<sup>1</sup>: Muffler clamp and aluminum spacer mounts to the outside of the stock muffler mount.**

**Note<sup>2</sup>: If required, loosen the (2) right passenger foot peg mount bolts to achieve proper alignment with muffler clamp.**

- 5. Torque muffler mount bolt to factory specification. If loosened, torque passenger foot peg mount bolts to factory specification.**
- 6. Torque exhaust clamp to 10 ft-lb (13.5 Nm).**
- 7. Before starting motorcycle, check for proper clearance between new exhaust system and rear suspension (i.e. tire, swing-arm, brake, rear shock, engine, and etc.) If any problem is found, please carefully follow through the installation steps again. If problem still persists, please call Yoshimura Tech Department at (800) 634-9166 / in CA (909) 628-4722.**
- 8. It is recommended that the muffler and tailpipe be wiped down with rubbing alcohol to remove oil and fingerprints. This will help prevent tarnishing of the finish after the exhaust is heated up.**

**NOTE: After starting motorcycle, it is normal for new exhaust system and muffler to emit smoke until oil residue burns off.**