



# YOSHIMURA

RESEARCH&DEVELOPMENT OF AMERICA, INC.

5420 DANIELS STREET STE A, CHINO CA., 91710 · (800)634-9166 · (909)628-4722 · FACSIMILE (909)591-2198

[www.yoshimura-rd.com](http://www.yoshimura-rd.com)

## *Signature Series*

### **Kawasaki Ninja 1000**

**14160E0220 (CF)**

**14160E0520 (SS)**

### **R-77 Slip-On Exhaust System**



This product is 50-state legal and complies with Federal and State regulations. Any attempts to modify this product will render it non-compliant with Federal law and void warranty. If modified, the vehicle can no longer be used on public roads and can only be used for off-highway closed course competition. In the state of California, it is illegal to modify the emission control system, which includes the fuel injection system of any vehicle.



## Assembly Diagram

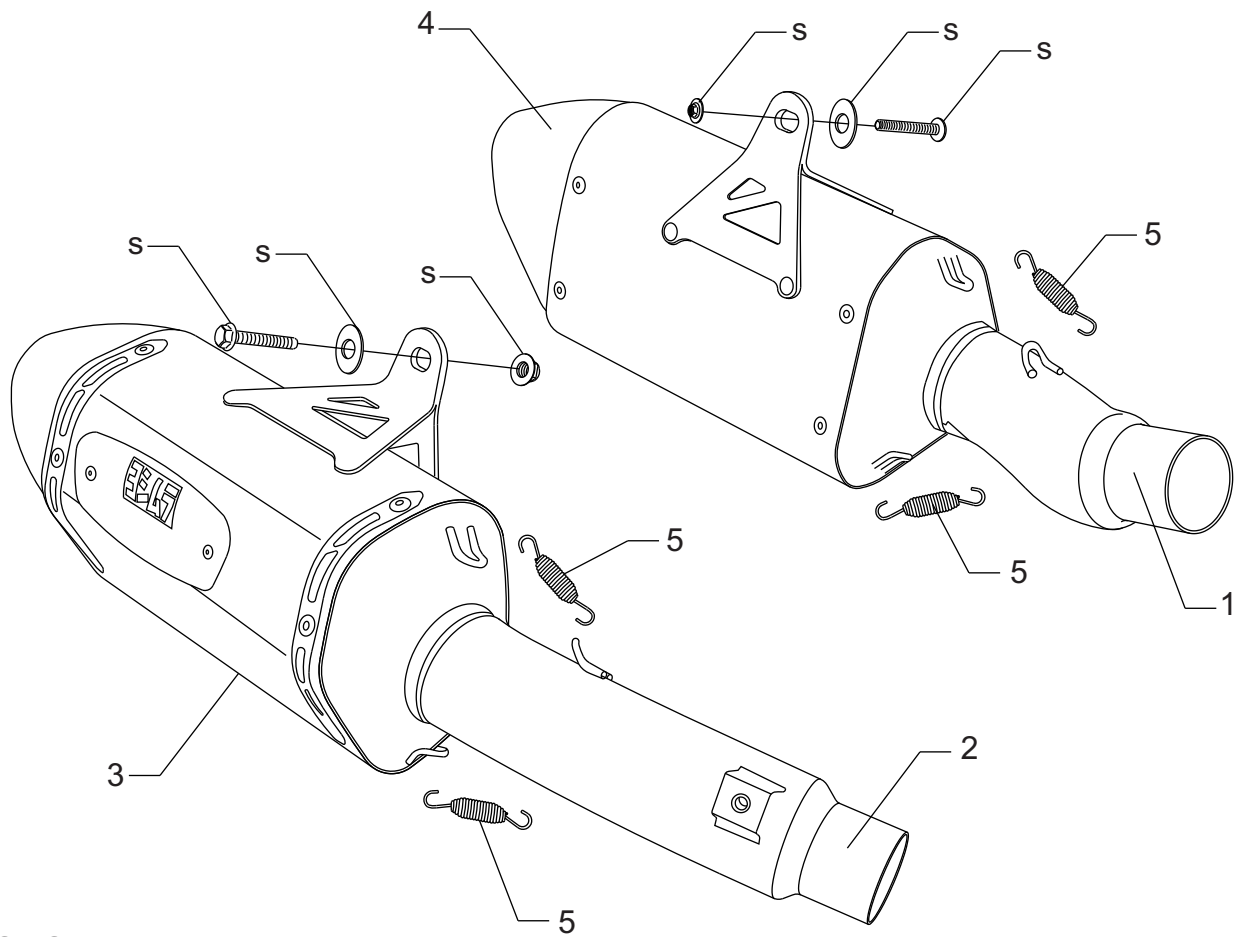

S - Stock

| No. | Item       | Description                    | Qty. |
|-----|------------|--------------------------------|------|
| 1   | 14160-426  | Yoshimura Left Tailpipe        | 1    |
| 2   | 14160-427  | Yoshimura Right Tailpipe       | 1    |
| 3   | ****       | Right Signature Series Muffler | 1    |
| 4   | ****       | Left Signature Series Muffler  | 1    |
| 5   | RACE-SPX-1 | Small Exhaust Spring           | 4    |
| **  | ST-200     | Spring Puller Tool             | 1    |
| **  | 17029      | Sticker Kit Sheet              | 1    |

\*\*\*\* Signature Series muffler replacement part number unavailable. Repair or replacement of Signature Series exhaust systems is only available directly through Yoshimura R&D of America, Inc.

## Removal

1. If equipped, remove left and right saddlebags according to the Factory Service / Owners Manual.
2. Remove right side muffler heatshield bolt and heatshield.
3. Loosen right side exhaust clamp.
4. While securely supporting the right muffler, remove the muffler mount bolt and carefully remove the muffler assembly by sliding toward the rear of the motorcycle.

Note: The stock exhaust gaskets will be re-used with the Yoshimura slip-on system. Inspect and replace if necessary.

5. Loosen left side exhaust clamp.
6. While securely supporting the left muffler, remove the muffler mount bolt and carefully remove the muffler assembly by sliding toward the rear of the motorcycle.

Note: The stock exhaust gaskets will be re-used with the Yoshimura slip-on system. Inspect and replace if necessary.

## Installation

1. Install the stock exhaust gasket onto (No. 1, 2) 14160-426/7, left and right tailpipe inlet.
2. Install right Yoshimura tailpipe and muffler assembly into the right header outlet.
3. Secure muffler bracket to muffler mount using the stock bolt, washer, and nut as shown in the diagram.

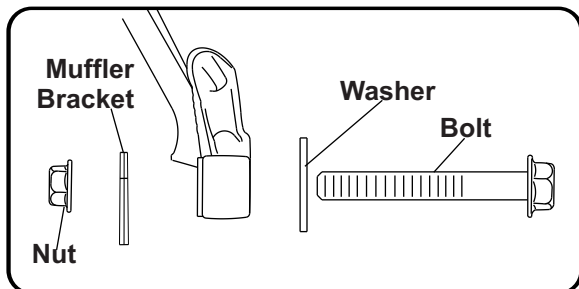

4. Torque right muffler mount bolt and exhaust clamp to factory specification.
5. Re-install the stock right side heatshield using the stock bolt. Torque to factory specification.

6. Install left side Yoshimura tailpipe and muffler assembly into the left header outlet.
7. Secure muffler bracket to muffler mount using the stock bolt, washer, and nut as shown in the diagram.

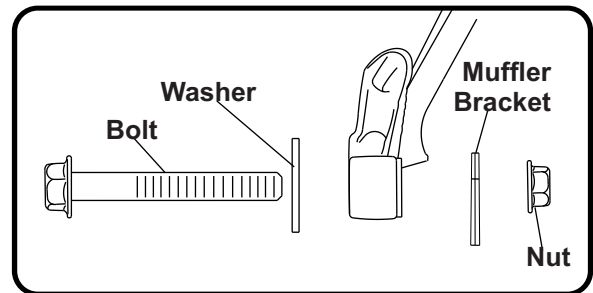

8. Torque left muffler mount bolt and exhaust clamp to factory specification.
9. If removed, re-install left and right saddlebags using the reverse steps of removal.
10. Before starting vehicle, check for proper clearance between new exhaust system and rear suspension (i.e. tire, control arms, brakes, rear shock, and etc.) If any problem is found, please carefully follow through the installation steps again. If problem still persists, please call Yoshimura Tech Department at (800) 634-9166 / in CA (909) 628-4722.
11. It is recommended that the muffler and tailpipe be wiped down with rubbing alcohol to remove oil and fingerprints. This will help prevent tarnishing of the finish after the exhaust is heated up.

Note: After starting motorcycle, it is normal for new exhaust system and muffler to emit smoke until oil residue burns off.

\* This page has been left blank intentionally.

## **NOISE EMISSION WARRANTY**

Yoshimura warrants that this exhaust system, at time of sale, meets all applicable U.S. E.P.A. Federal noise standards. This warranty extends to the first person who buys this exhaust system for purposes other than resale, and to all subsequent buyers. Warranty claims should be directed to Yoshimura R&D of America, Inc. 5420 Daniels St. Chino, CA 91710 | Tel (800) 634-9166

## **TAMPERING PROHIBITION**

Federal law prohibits any modification to this exhaust system which causes the motorcycle to exceed the Federal noise standard. Use of the motorcycle with such a modified exhaust system is also prohibited.

Acts likely to constitute tampering include removal or puncturing the muffler, baffles, header pipes, or any other component which conducts exhaust gases.

**WARNING: This product should be checked for repair or replacement if the motorcycle noise has increased significantly through use. Otherwise, the owner may become subject to penalties under state and local ordinances.**