



# YOSHIMURA

RESEARCH&DEVELOPMENT OF AMERICA, INC.

5420 DANIELS STREET STE A, CHINO CA., 91710 · (800) 634-9166 · (909) 628-4722 · FACSIMILE (909) 591-2198

[www.yoshimura-rd.com](http://www.yoshimura-rd.com)

## *Signature Series*

### **Yamaha R3**

**13320EJ220 (CF/CF)**

**13320EJ520 (SS/CF)**

### **R77 Stainless Steel Slip-On**

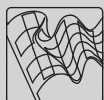

Signature Series systems are:

- CARB/EPA tail-pipe emissions compliant.
- Marked with appropriate EPA noise labels.
- Independent laboratory tested for EPA new vehicle noise compliance.

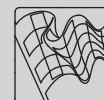

✘ You must know how to remove and replace your stock exhaust in order to install this product otherwise have it installed by a professional mechanic. Keep all stock parts from your existing system as some components may be necessary to install your new Yoshimura exhaust depending on the application. Read through all instructions before beginning installation. Exhaust system can be extremely hot. Let motorcycle cool down before beginning installation. Always wear hand and eye protection and take precautionary measures to avoid injury. ✘

NOTE: IN THE STATE OF CALIFORNIA, IT IS ILLEGAL TO MODIFY THE EMISSION CONTROL SYSTEM, WHICH INCLUDES THE CARBURETORS OF ANY VEHICLE.

## Assembly Diagram

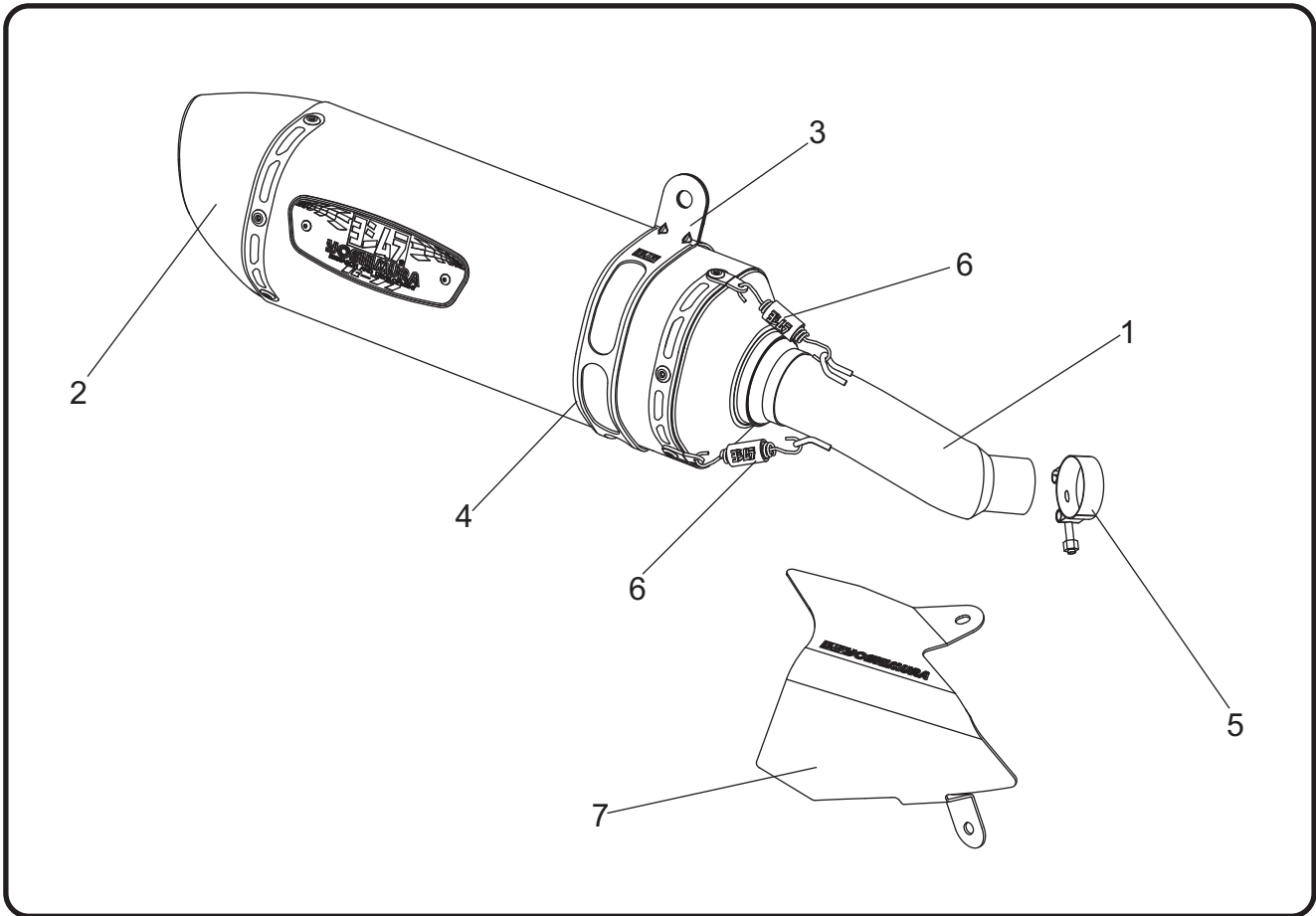

No.	Item	Description	Qty.
1	13320-435	Yoshimura Tailpipe	1
2	****	Signature Series Muffler	1
3	YM7M-MPCA(X)	Muffler Clamp	1
4	HT SHLDR77	Muffler Clamp Heat Insulator	1
5	22053	Exhaust Clamp	1
6	RACE-SPS-1	Medium Exhaust Spring	2
7	13320-HS	Muffler Heatshield	1
**	17029	Sticker Sheet	1
**	ST-200	Spring Puller Tool	1

(X) For use with Stainless Steel canister.

\*\* Not Shown on diagram.

\*\*\*\* Signature Series muffler replacement part number unavailable. Repair or replacement of Signature Series exhaust systems is only available directly through Yoshimura R&D of America, Inc.

## Removal

1. Loosen the stock exhaust clamp at the muffler and header connection.
2. While securely supporting the stock muffler, remove the muffler mount bolt and carefully remove the stock muffler.

Note: The stock exhaust gasket will not be used with the slip-on system.

3. Remove the two rear (upper and lower) header heatshield bolts.

## Installation

1. Slide (No. 5) 22053, exhaust clamp over the inlet of (No. 1) 13320-435, tailpipe as shown.

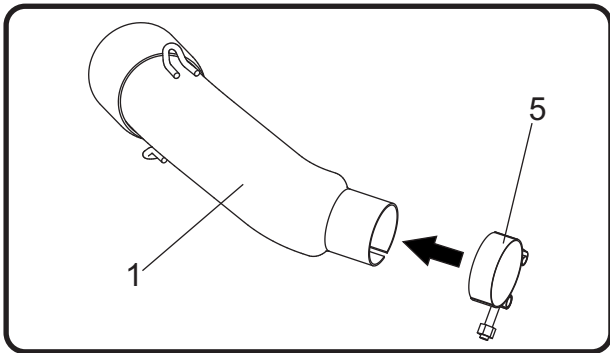

2. Install (No. 1) 13320-435, tailpipe over the stock header outlet.
3. Install (No. 4) HT SHLDR77, muffler clamp heat insulator onto (No. 3) YM7M-MPCA(X), muffler clamp.

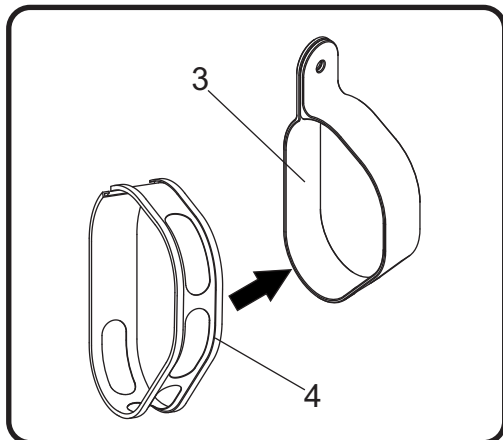

4. Slide (No. 3) YM7M-MPCA(X), muffler clamp over (No. 2) Muffler and align and secure to the stock muffler mount using the stock bolt, washer, and nut.

Note: The muffler clamp mounts to the outside of the stock muffler mount.

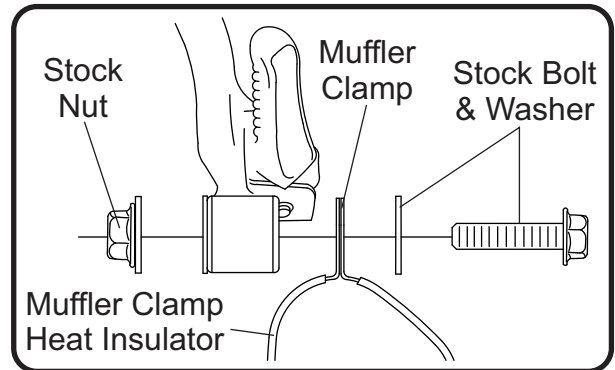

5. Torque the stock muffler mount bolt to factory specification.
6. Torque (No. 5) 22053, exhaust clamp to 8.5 Nm (0.85 kg-m, 6 ft-lb).
7. Install (No. 7) 13320-HS, muffler heatshield between the header heatshield bracket and the stock header heatshield using the two rear (upper and lower) header heatshield bolts removed previously. Torque heatshield bolts to factory specification.

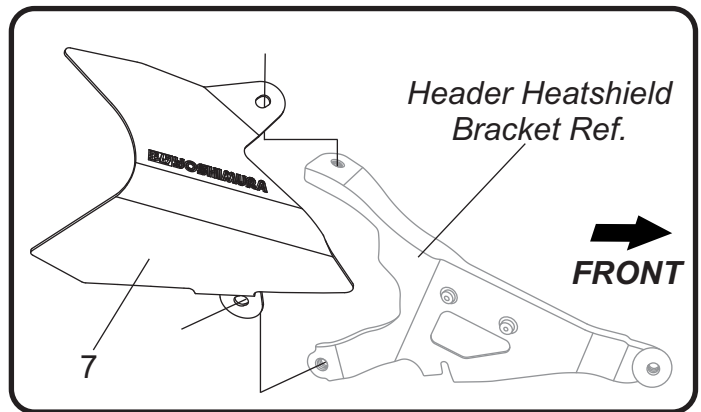

8. Before starting vehicle, check for proper clearance between new exhaust system and rear suspension (i.e. tire, swingarm, brakes, rear shock, and etc.) If any problem is found, please carefully follow through the installation steps again. If problem still persists, please call Yoshimura Tech Department at (800) 634-9166 / in CA (909) 628-4722.
9. It is recommended that the muffler and tailpipe be wiped down with rubbing alcohol to remove oil and fingerprints. This will help prevent tarnishing of the finish after the exhaust is heated up.

Note: After starting motorcycle, it is normal for new exhaust system and muffler to emit smoke until oil residue burns off.

**This Page Has Been  
Intentionally Left Blank**

## **NOISE EMISSION WARRANTY**

Yoshimura warrants that this exhaust system, at time of sale, meets all applicable U.S. E.P.A. Federal noise standards. This warranty extends to the first person who buys this exhaust system for purposes other than resale, and to all subsequent buyers. Warranty claims should be directed to Yoshimura R&D of America, Inc. 5420 Daniels St. Chino, CA 91710 | Tel (800) 634-9166

## **TAMPERING PROHIBITION**

Federal law prohibits any modification to this exhaust system which causes the motorcycle to exceed the Federal noise standard. Use of the motorcycle with such a modified exhaust system is also prohibited.

Acts likely to constitute tampering include removal or puncturing the muffler, baffles, header pipes, or any other component which conducts exhaust gases.

**WARNING: This product should be checked for repair or replacement if the motorcycle noise has increased significantly through use. Otherwise, the owner may become subject to penalties under state and local ordinances.**