



PERFORMANCE EXHAUST SYSTEM

APPLICATION

YEAR	MODEL
2011	Honda CBR250R

PRODUCT

1225027220	TRC SS Slip-On Exhaust System with Carbon Fiber Sleeve; Carbon Fiber Endcap
1225027520	TRC SS Slip-On Exhaust System with Stainless Steel Sleeve; Carbon Fiber Endcap
1225027550	TRC SS Slip-On Exhaust System with Stainless Steel Sleeve; Stainless Steel Endcap

- ⚠ *This product is designed for use in closed course racing and is not intended for highway use. In the state of California, it is illegal to modify the emission control system, which includes the fuel injection of any vehicle.*
- ⚠ *You must know how to remove and replace your stock exhaust in order to install this product otherwise have it installed by a professional mechanic. Keep all stock parts from your existing system as some components may be necessary to install your new Yoshimura exhaust depending on the application.*
- ⚠ *Read through all instructions before beginning installation. Exhaust system can be extremely hot. Let motorcycle cool down before beginning installation. Always wear hand and eye protection and take precautionary measures to avoid injury.*

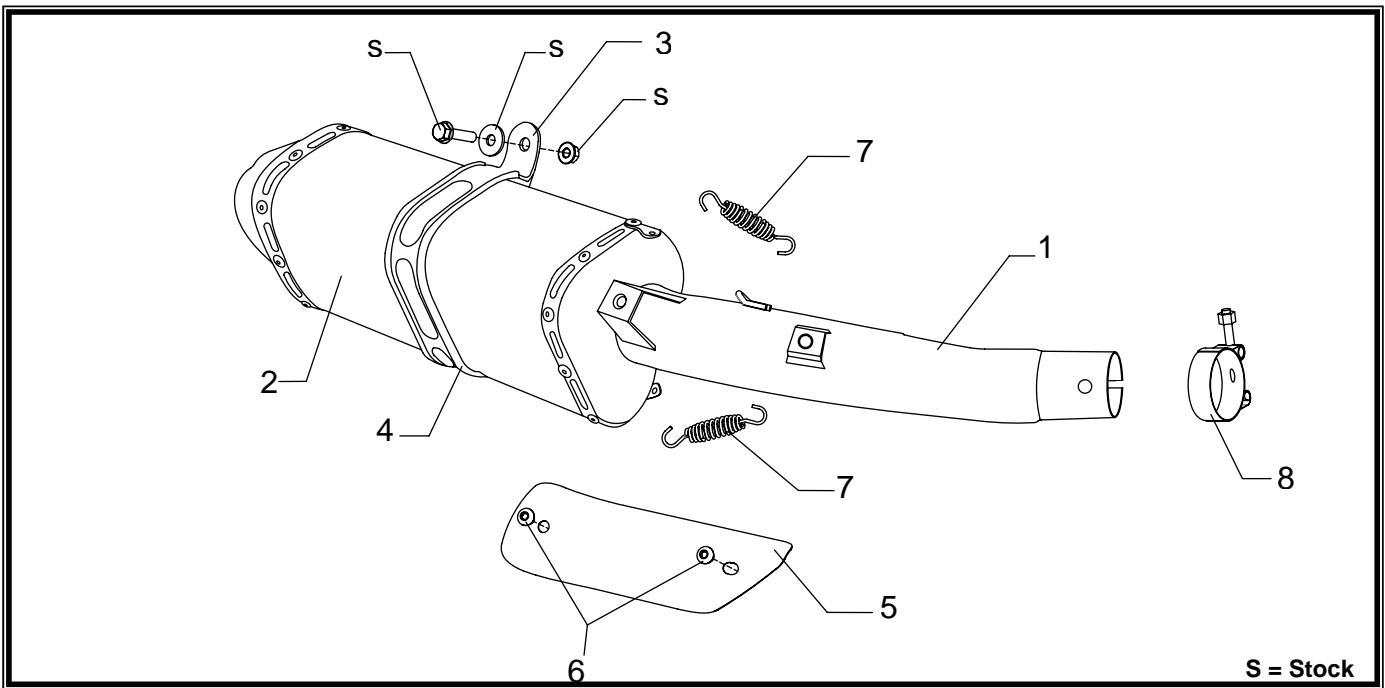

No.	Part #	Description	Qty
1	12250-435	Yoshimura Tailpipe	1
2	1406272-RMA 1225007520-RMA 1406275-RMA	Yoshimura Muffler CF Sleeve; CF Endcap SS Sleeve; CF Endcap SS Sleeve; SS Endcap	1
3	CTS081 CTS081X	Muffler Clamp Carbon Fiber Sleeve Stainless Steel Sleeve	1
4	HT SHLDTRS	Muffler Clamp Heatshield	1
5	1121-HSR	Yoshimura Heatshield	1
6	RC116HSB	6mm x 8mm Button Head Cap Screw	2
7	RACE-SPS-1	Medium Spring	2
8	22055	Exhaust Clamp	1
**	S-RIVET	Securing Rivet	1
**	ST-200	Spring Puller Tool	1
**	TRC-INS-K	Low Vol. Sound Insert	1
**	17029	Yoshimura Sticker Sht	1

-TOOLS REQUIRED-

Metric Socket Set
Combination Wrench Set
Torque Wrench
Metric Allen Wrench Set
Power Drill
3/16" Drill Bit

-REMOVAL-

1. *Removing the muffler.*

- a) **Loosen the muffler clamp on the tailpipe.**
- b) **While securely supporting the muffler, remove the muffler mount bolt that holds the muffler assembly to subframe.**
- c) **Carefully slide the stock muffler assembly off of header.**
Note: The stock exhaust gasket will not be used with the Yoshimura Slip-On system.

-INSTALLATION-

1. *Installing the muffler tailpipe assembly.*

- a) **Slide provided exhaust clamp over Yoshimura tailpipe.**
- b) **Install rubber heatshield onto muffler clamp.**
- c) **Slide muffler clamp over Yoshimura muffler.**
- d) **Slide Yoshimura muffler assembly over stock header.**
- e) **Align muffler clamp to muffler mount and secure using stock bolt, washer, and nut. See diagram for orientation.**
- f) **Standing at the back of the motorcycle, check for proper alignment of the muffler. Adjust if necessary. Note: To adjust fitment, it may be necessary to rotate the tailpipe or the muffler independently until proper alignment of the muffler is achieved.**
- g) **A securing rivet will be installed in the tailpipe to prevent the tailpipe from rotating while the motorcycle is in operation. Drill a 3/16" hole through the outlet of the stock header using the securing holes located near the Yoshimura tailpipe inlets as your guide.**
CAUTION: Always wear eye protection when using any power tools.
- h) **Insert securing rivet into drilled hole and slide exhaust clamp over rivet and torque to 13 Nm (1.3 kg-m, 10 ft-lb).**
- i) **Torque muffler mount bolt to 23 Nm (2.3 kg-m, 16.5 ft-lb).**
- j) **Install provided heatshield onto tailpipe using the provided screws.**
Torque to 10 Nm (1 kg-m, 7 ft-lb).

2. *Fitment check and Notes.*

- a) **Before starting motorcycle, check for proper clearance between new exhaust system and rear suspension (i.e. tire, swing-arm, brake, rear shock, engine, and etc.) If any problem is found, please carefully follow through the installation steps again. If problem still persists, please call Yoshimura Tech Department at (800) 634-9166 / in CA (909) 628-4722.**
- b) **It is recommended that the muffler and tailpipe be wiped down with rubbing alcohol to remove oil and fingerprints. This will help prevent tarnishing of the finish after the exhaust is heated up.**
- c) **NOTE: After starting motorcycle, it is normal for new exhaust system and muffler to emit smoke until oil residue burns off.**