





PERFORMANCE EXHAUST SYSTEM

APPLICATION

YEAR	MODEL
2012	Suzuki GSX-R1000

PRODUCT

1118123220	R77D Stainless Steel Slip-On Exhaust System with Carbon Fiber Sleeve; Carbon Fiber Endcap
1118123520	R77D Stainless Steel Slip-On Exhaust System with Stainless Steel Sleeve; Carbon Fiber Endcap

- 
 This product is designed for use in closed course racing and is not intended for highway use. In the state of California, it is illegal to modify the emission control system, which includes the fuel injection of any vehicle.
- 
 You must know how to remove and replace your stock exhaust in order to install this product otherwise have it installed by a professional mechanic. Keep all stock parts from your existing system as some components may be necessary to install your new Yoshimura exhaust depending on the application.
- 
 Read through all instructions before beginning installation. Exhaust system can be extremely hot. Let motorcycle cool down before beginning installation. Always wear hand and eye protection and take precautionary measures to avoid injury.

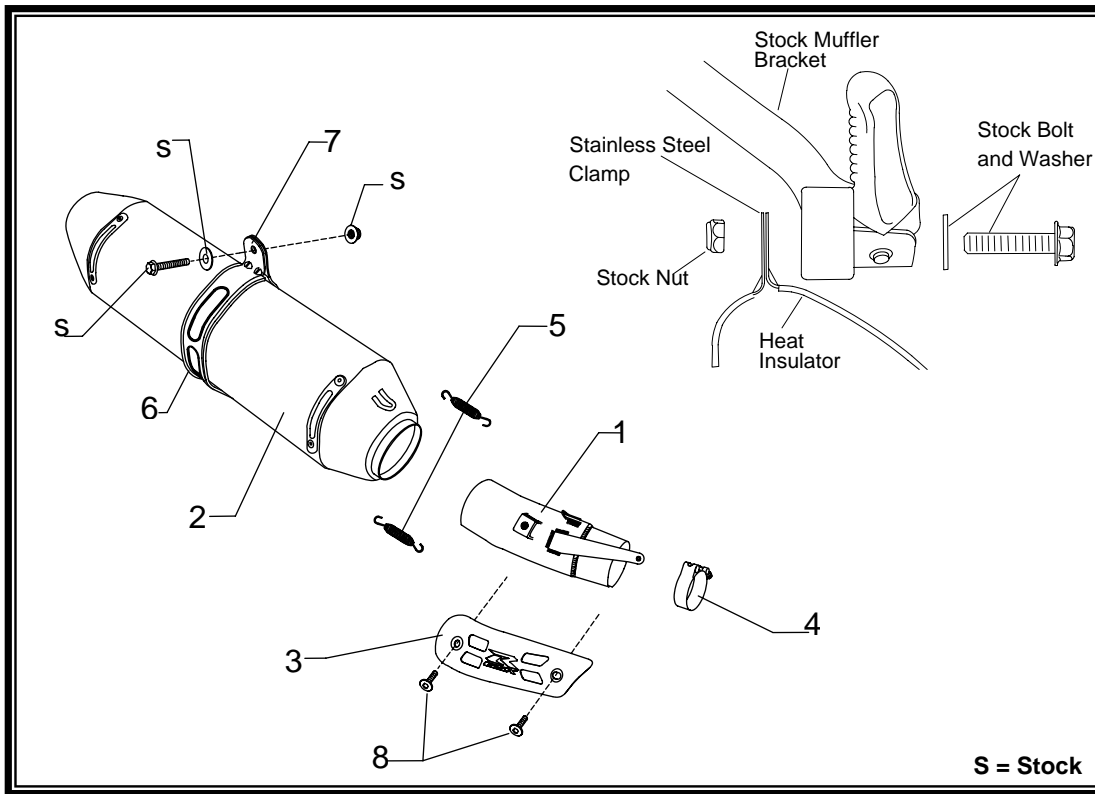

No.	Part #	Description	Qty
1	11181-435	Yoshimura Tailpipe	1
2	CRR77D126W SRR77D126W	Yoshimura Muffer Carbon Fiber Sleeve Stainless Steel Sleeve	1
3	1117-HSR	Yoshimura Heatshield	1
4	20062	Exhaust Clamp	1
5	RACE-SPS-1	Medium Spring	2
6	HT SHLDR77	Muffer Clamp Insulator	1
7	1121-MPCA 1121-MPCAX	Muffer Clamp CF Sleeve SS Sleeve	1
8	RC116HSB	Heatshield Screw	2
**	ST-200	Spring Puller Tool	1
**	17029	Yoshimura Sticker Sheet	1

-TOOLS REQUIRED-

Metric Socket Set

Combination Wrench Set

Torque Wrench

Metric Allen Wrench Set

-REMOVAL-

1. *Removing the muffler.*

- a) **Loosen the muffler clamp on the tailpipe.**
- b) **While securely supporting the muffler, remove the muffler mount bolt.**
- c) **Remove the stock muffler.**

Note: Exhaust gasket will not be used with the Yoshimura Slip-On System.

-INSTALLATION-

1. *Installing the Yoshimura Slip-On System.*

- a) **Slide provided exhaust clamp onto Yoshimura tailpipe.**
- b) **Install rubber heat insulator onto muffler clamp.**
- c) **Slide muffler clamp over Yoshimura muffler.**
- d) **Mount Yoshimura muffler clamp to the inside of the stock muffler mount bracket using stock hardware.**
- e) **Torque exhaust clamp to 12Nm (1.2kg-m, 9lb-ft).**
- f) **Torque muffler clamp bolt to 24Nm (2.4kg-m, 18lb-ft).**

Note: To adjust fitment, it may be necessary to rotate the tailpipe or the muffler independently until proper alignment of the muffler is achieved. Remove exhaust springs to ease adjustment.

2. *Fitment check and Notes.*

- a) **Before starting motorcycle, check for proper clearance between new exhaust system and rear suspension (i.e. tire, swing-arm, brake, rear shock, engine, and etc.) If any problem is found, please carefully follow through the installation steps again. If problem still persists, please call Yoshimura Tech Department at (800) 634-9166 / in CA (909) 628-4722.**
- b) **It is recommended that the muffler and tailpipe be wiped down with rubbing alcohol to remove oil and fingerprints. This will help prevent tarnishing of the finish after the exhaust is heated up.**
- c) **NOTE: After starting motorcycle, it is normal for new exhaust system and muffler to emit smoke until oil residue burns off.**