



YOSHIMURA

RESEARCH&DEVELOPMENT OF AMERICA, INC.

5420 DANIELS STREET STE A, CHINO CA., 91710 · (800)634-9166 · (909)628-4722 · FACSIMILE (909)591-2198

www.yoshimura-rd.com

FENDER ELIMINATOR KIT

070BG142000
Kawasaki H2

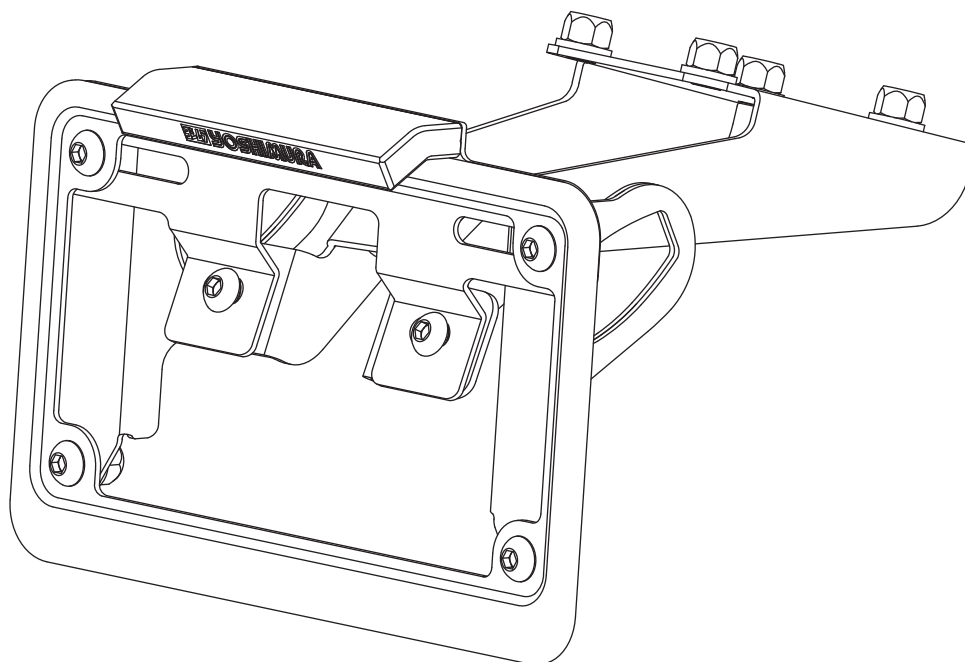

THIS PRODUCT IS NOT DOT APPROVED.

Yoshimura R&D of America, Inc. is not liable or responsible for any resulting event caused by the installation of this product. Check with local laws and regulations for compliance prior to installation and use. This product is not intended for use on public highways.



Assembly Diagram

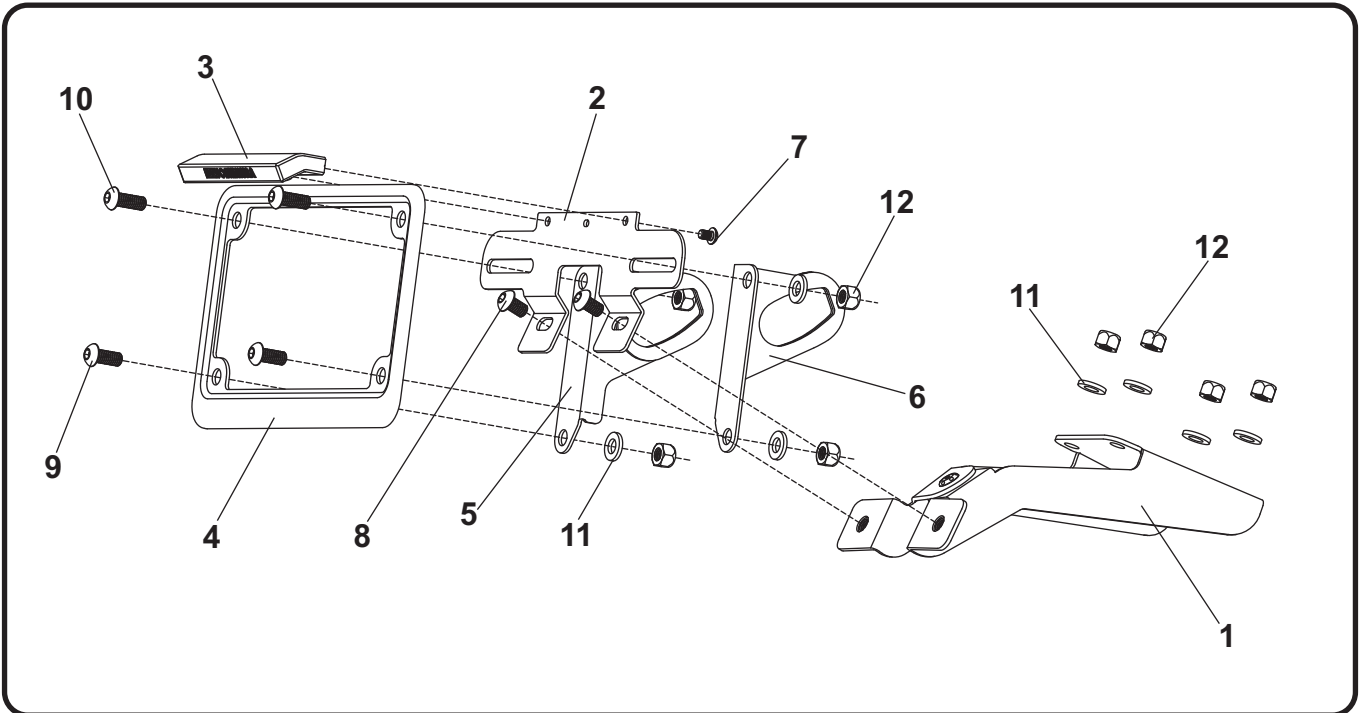

No.	Item	Description	Qty.
1	14200-FEBKT	Fender Eliminator Bracket	1
2	12200-FEBKT	License Plate Bracket	1
3	070BG-LH-K	LED License Plate Light	1
4	070BG-LPF	License Plate Frame	1
5	14200-TSL	Left Turn Signal Bracket	1
6	14200-TSR	Right Turn Signal Bracket	1
7	M4X6BHS	4mm x 6mm Button Head Screw	2
8	M6X10BHS	6mm x 10mm Button Head Screw	2
9	M6X14BHS	6mm x 14mm Button Head Screw	2
10	M6X16BHS	6mm x 16mm Button Head Screw	2
11	6MMWASHER	6mm Washer	8
12	6MMLN	6mm Nylon Lock Nut	8
**	94785-01-ND	Butt Connectors	2
**	ZT-400	Cable Ties	3
**	17029	Yoshimura Sticker Sheet	1
Optional Parts			
***	070BGUNVTBKT	Universal Turn Signal Bracket Kit	

** Not shown on diagram.

*** The Yoshimura Universal Turn Signal Bracket Kit is to be used with aftermarket stud-mounted turn signals and is sold separately.

Removal

1. Remove rear seat pad.
2. Locate and disconnect the license plate light and turn signal connectors.
3. While securely supporting the stock fender assembly, remove the four bolts securing the fender assembly to the subframe. Carefully remove the stock fender assembly making sure not to damage the connectors in the process.
4. Disassemble the stock fender assembly and disconnect turn signal connectors from sub-harness.

Note: The sub-harness secured to the stock fender assembly will be re-used. Cut cable ties securing sub-harness to fender assembly and remove.

5. Remove the left and right turn signals from the stock fender assembly.
6. Cut the stock license plate light connector from the stock fender assembly. Be sure to cut at least a 6" section of wire from the connector.

Installation

1. Install (No. 1) 14200-FEBKT, fender eliminator bracket to subframe using the stock fender bolts and supplied (No. 11,12) 6MMWASHER and 6MMLN, washer and nut.

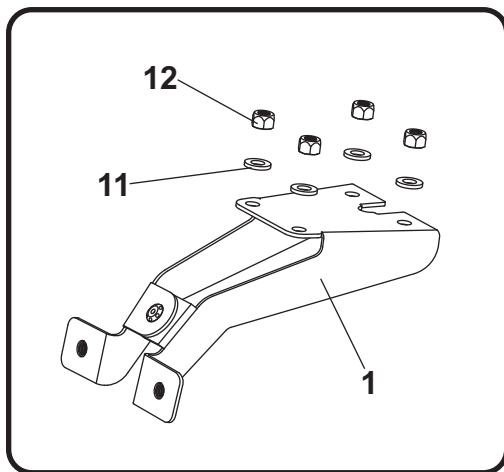

2. Using (No. 7) M4X6BHS screw, install (No. 3) 070BG-LH-K, license plate light onto (No. 2) 12200-FEBKT, license plate bracket.

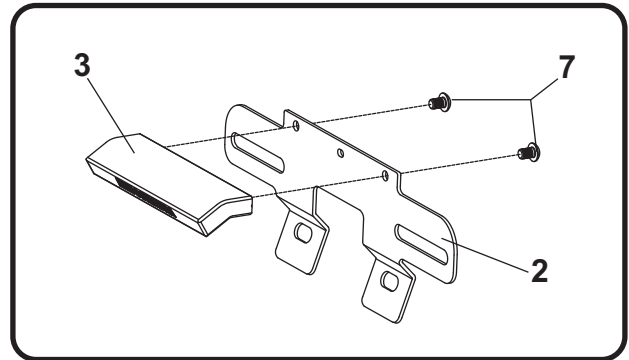

3. Using the 94785-01-ND butt connectors provided in the kit, connect the Yoshimura license plate light wires to the stock license plate light wires as follows:

Red -to- Red
Black/Yellow -to- Black

4. Install (No. 2) 12200-FEBKT, license plate bracket to (No. 1) 14200-FEBKT, fender eliminator bracket using (No. 8) M6X10BHS, screws.

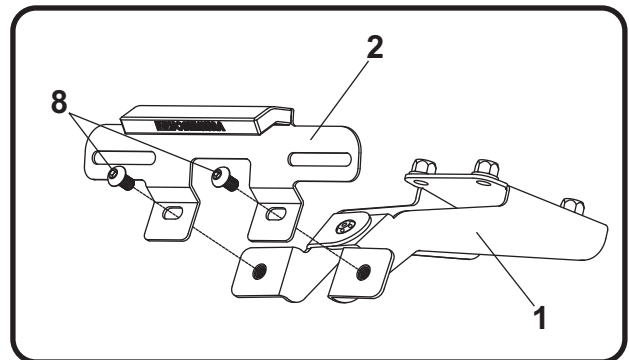

5. Install stock left and right turn signals onto (No. 5,6) 14200-TSL/R, left and right turn signal brackets.
6. Install (No. 5,6) 14200-TSL/R, left and right turn signal brackets and (No. 4) 070BG-LPF, license plate frame using the (No. 9,10) M6X14BHS and M6X16BHS, 6mm button head screws as shown below.

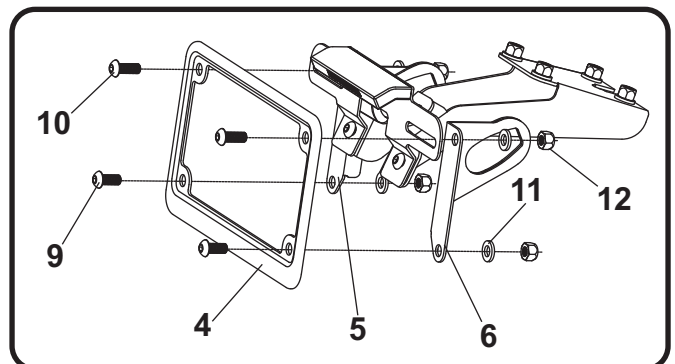

7. Re-connect the stock fender sub-harness to turn signal connectors.
8. Re-connect sub-harness and license plate light connectors beneath the rear seat pad.
9. Use the cable ties provided in the kit to secure license plate light and turn signal wires.
10. Re-install rear seat pad.
11. Check for proper function of license plate light and turn signals and that all brackets and components are secure prior to riding.