



Fender Eliminator Kit

APPLICATION

YEAR	MODEL
2010-2013	Kawasaki Ninja 1000 / Z1000
PRODUCT	
070BG141502	Fender Eliminator Kit



This product is not DOT approved. Yoshimura R&D of America, Inc. is not liable or responsible for any resulting event caused by the installation of this product. Check with local laws and regulations for compliance prior to installation and use. This product is not intended for use on public highways.

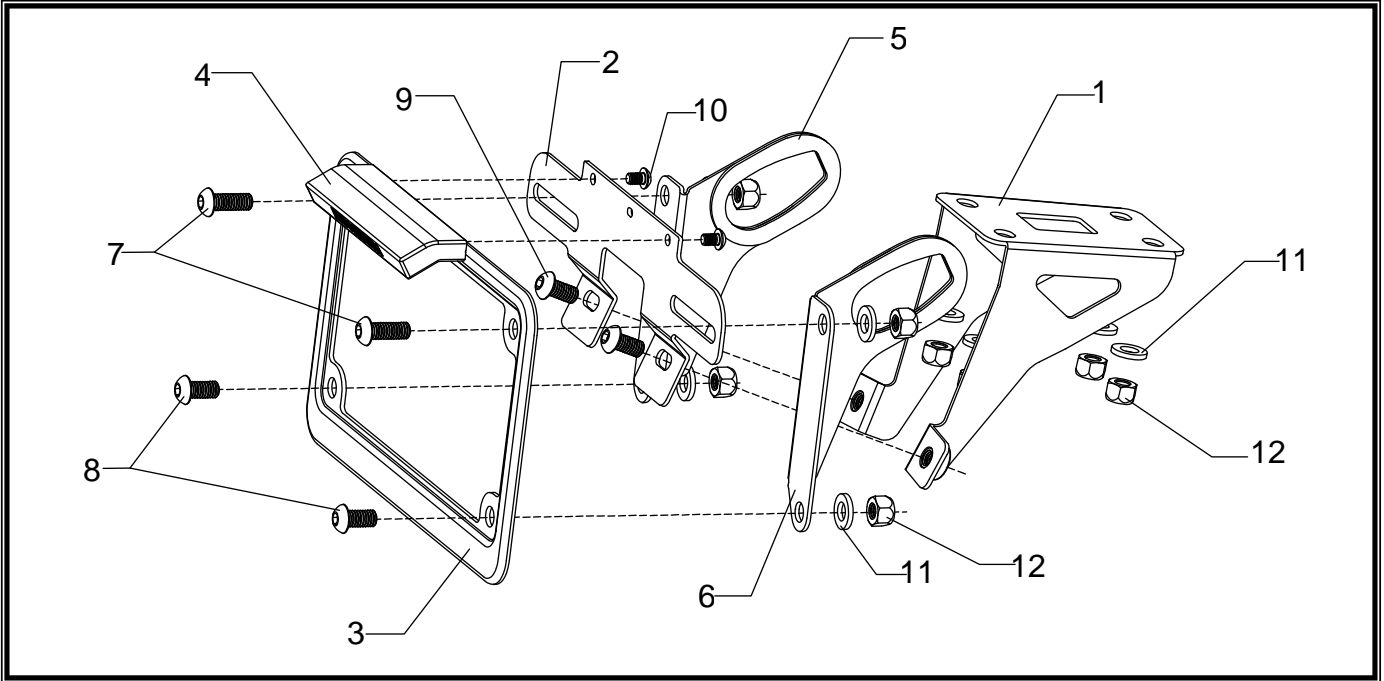

No.	Part #	Description	Qty
1	14150-FEBKT	Yoshimura Fender Eliminator Bracket	1
2	12200-FEBKT	Yoshimura License Plate Bracket	1
3	070BG-LPF	Aluminum License Plate Frame	1
4	070BG-LH-K	Yoshimura LED Fender Eliminator Light	1
5	14650-TSL-BKT	Left Turn Signal Bracket	1
6	14650-TSR-BKT	Right Turn Signal Bracket	1
7	M6X16BHS	6mm x 16mm Button Head Screw	2
8	M6X12BHS	6mm x 12mm Button Head Screw	2
9	M6X10BHS	6mm x 10mm Button Head Screw	2
10	M4X6BHS	4mm x 6mm Button Head Screw	2
11	6MMWASHER	6mm Washer	8
12	6MMLN	6mm Lock Nut	8
**	94785-01-ND	Butt Connectors	2
**	ZT-300	Cable Ties	3
**	17029	Yoshimura Sticker Sheet	1

-TOOLS REQUIRED-

Metric Socket Set • Combination Wrench Set • Metric Allen Wrench Set • Screwdriver

-REMOVAL-

- 1. Remove passenger and rider seat as per Factory Service Manual.**
- 2. Z1000 See 3a. Ninja 1000 see 3b.**
- 3a.**
 - 1) Disconnect license plate light and turn signal wires.**
 - 2) Remove the (4) screws and the (2) tapping screws securing the stock fender assembly onto subframe.**
- 3b.**
 - 1) Remove the (4) screws securing the stock fender assembly onto subframe.**
 - 2) Remove the (2) bolts securing left and right passenger handle grips onto subframe.**
 - 3) Remove the (4) bolts securing upper tail cowl.**
 - 4) Carefully remove cowl by sliding toward the rear of the bike.**
 - 5) Carefully pull down on lower tail section.**
 - 6) Remove the (2) tapping screws securing the fender assembly onto lower tail section.**
 - 7) Disconnect license plate light and turn signal wires.**
- 4. Carefully remove the stock fender assembly.**
- 5. Remove turn signals from stock fender assembly and install onto Yoshimura turn signal brackets.**
- 6. Cut the stock license plate light connector from the stock fender assembly. BE SURE TO CUT AT LEAST A 6" SECTION OF WIRE FROM THE CONNECTOR.**

-INSTALLATION-

- 1. Install Yoshimura LED fender eliminator light onto license plate bracket.**
- 2. Using the connectors provided in the kit, connect the Yoshimura Fender Eliminator wires to the stock license plate light connector as follows: Red wire goes to Red wire; Black wire goes to black w/ yellow stripe.**
- 3. Assemble and install Yoshimura Fender Eliminator kit as shown in the parts diagram.**
- 4. Route license plate light and turn signal wires and pull through from underneath tail section. Connect license plate light connector and turn signal connectors to stock harness. Use provided cable ties to secure wires beneath the seat.**
- 5. For Ninja 1000, lift lower tail section back up to the subframe and secure using the provided hardware.**
- 6. Secure assembled Yoshimura Fender eliminator to subframe using the stock bolts in conjunction with the washers and nuts provided in the kit.**
- 7. Re-install rider and passenger seat using the reverse steps of removal.**
- 8. Check for function of license plate light and that all brackets and pieces are secure prior to riding.**